

Top Level

version 10, edit 2

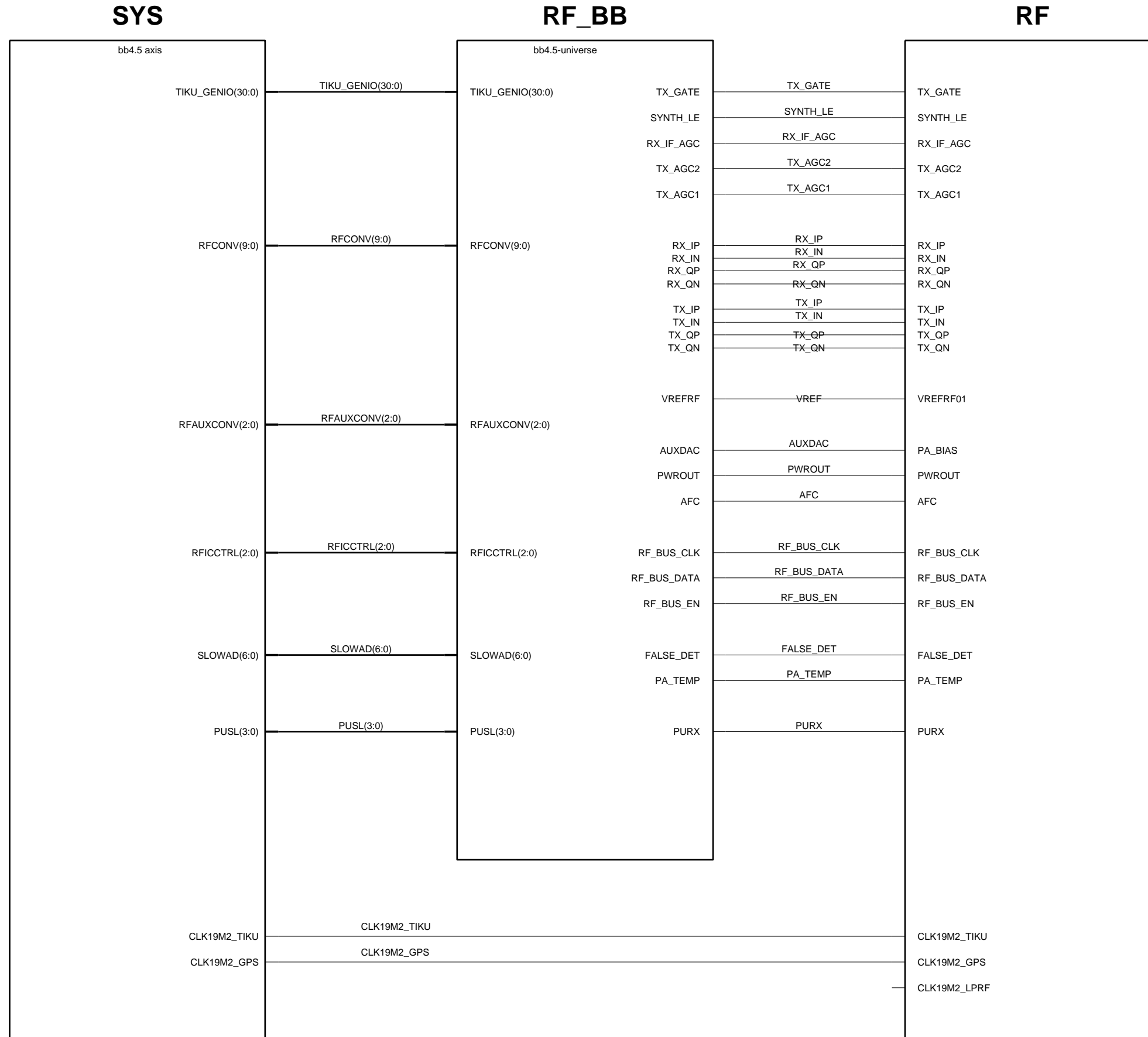

Baseband - Top Level

version 10, edit 2

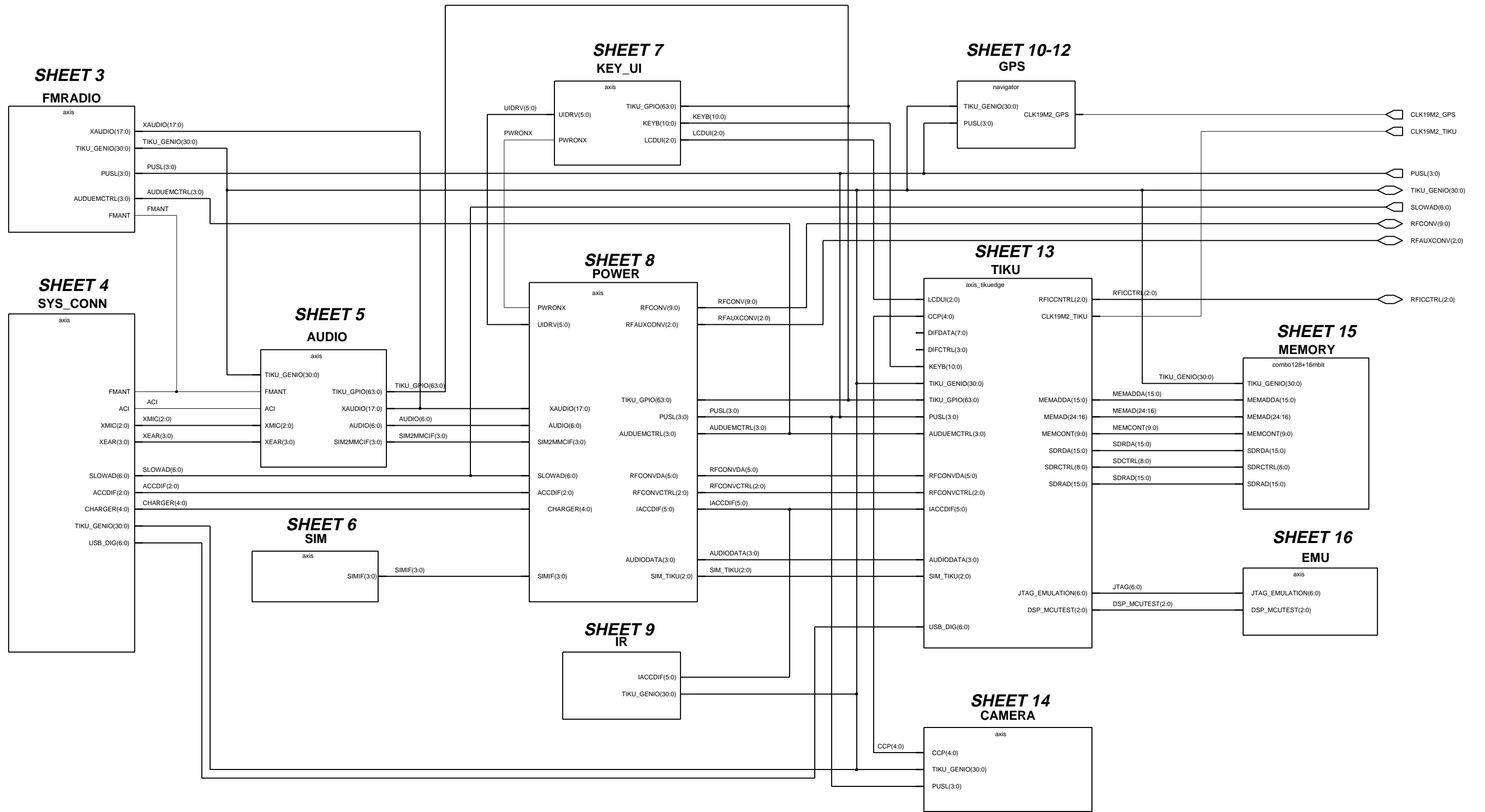

FM Radio

version 10, edit 4

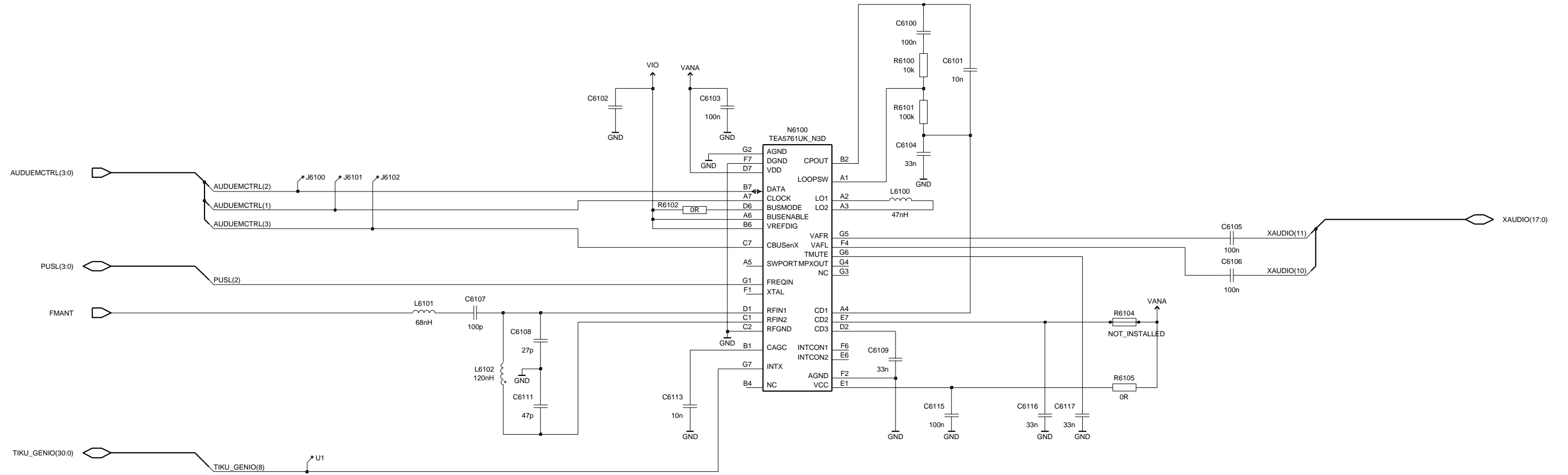

System Connector

version 10, edit 6

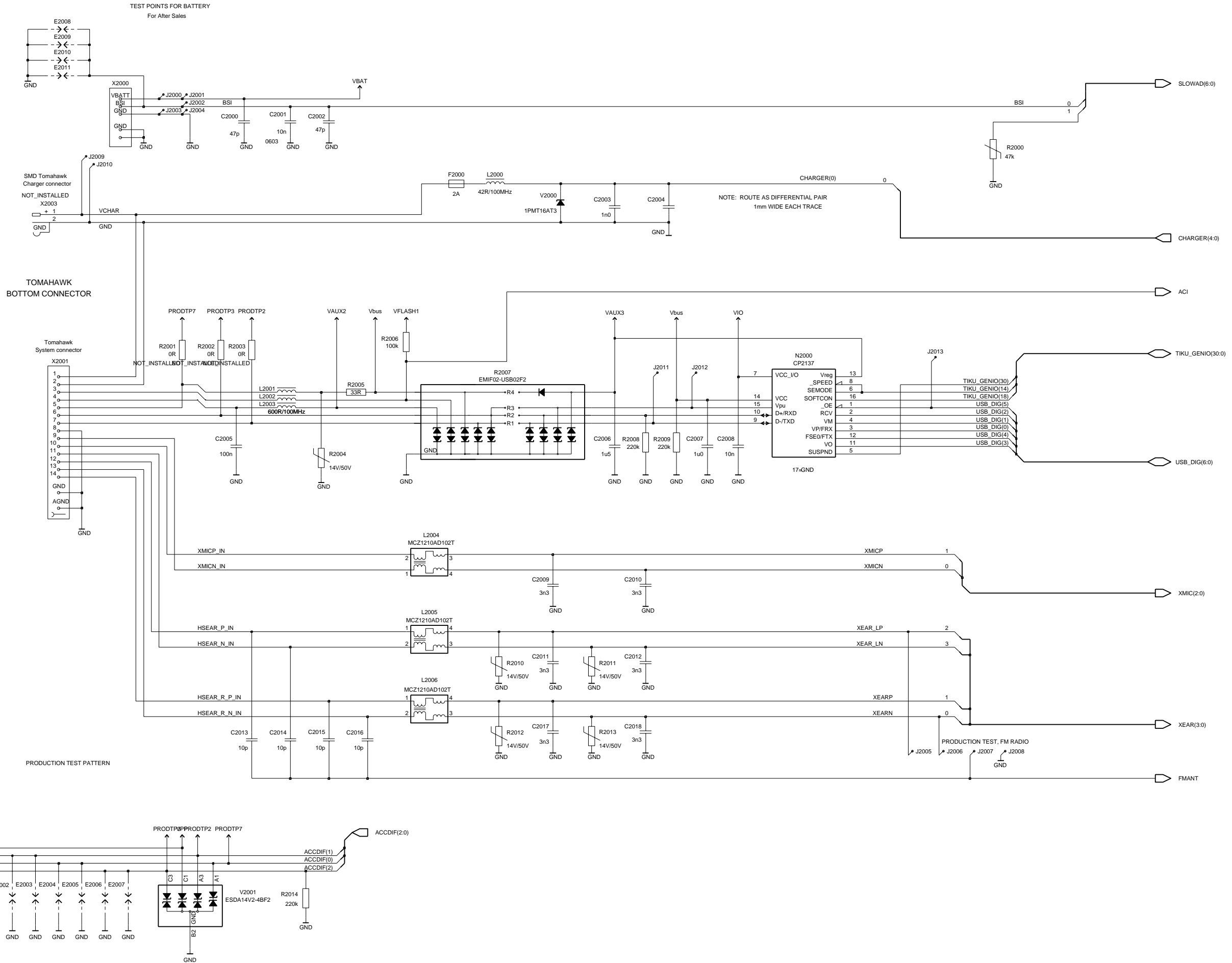

Audio

version 10, edit 4

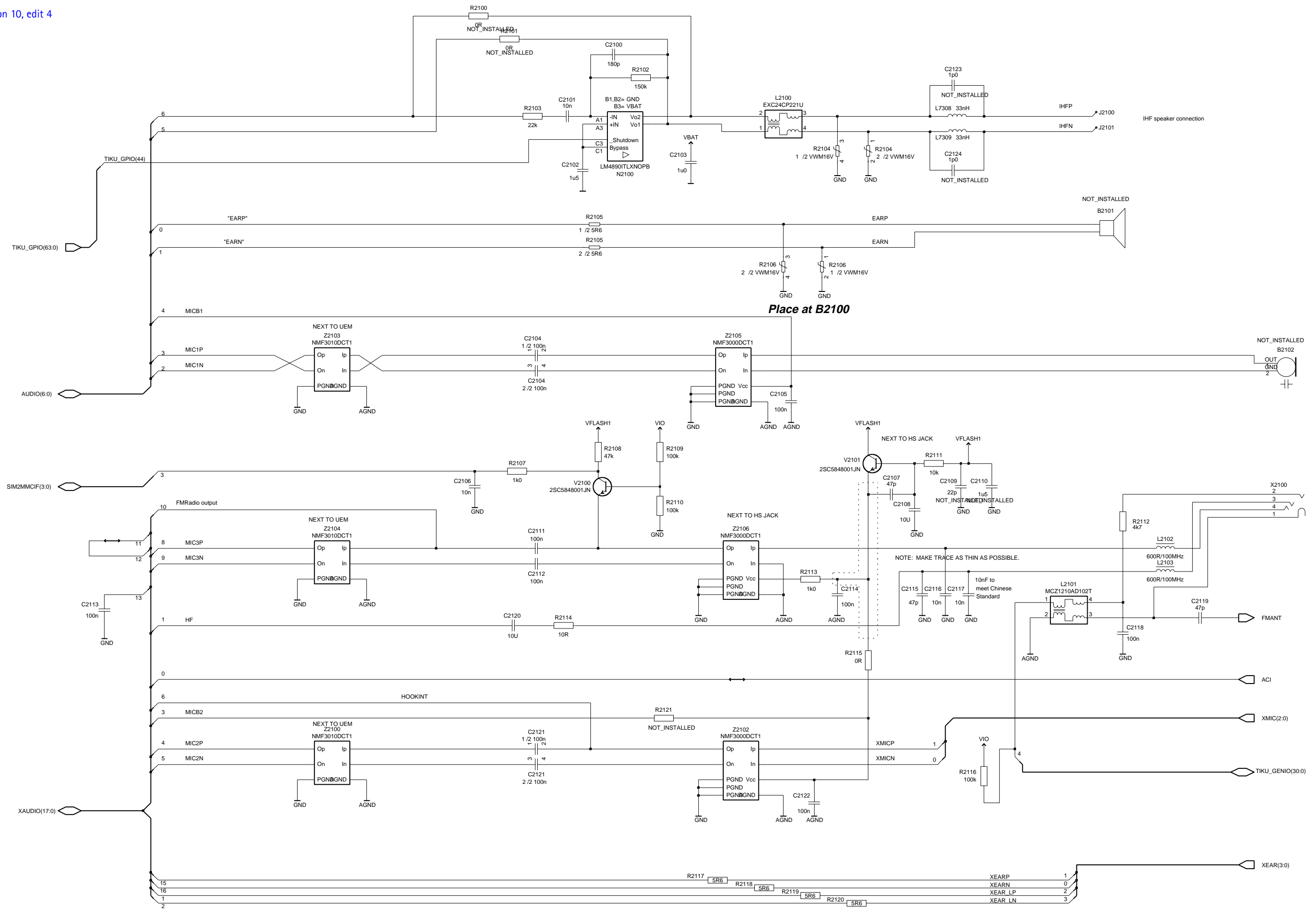

SIM Card

version 10, edit 3

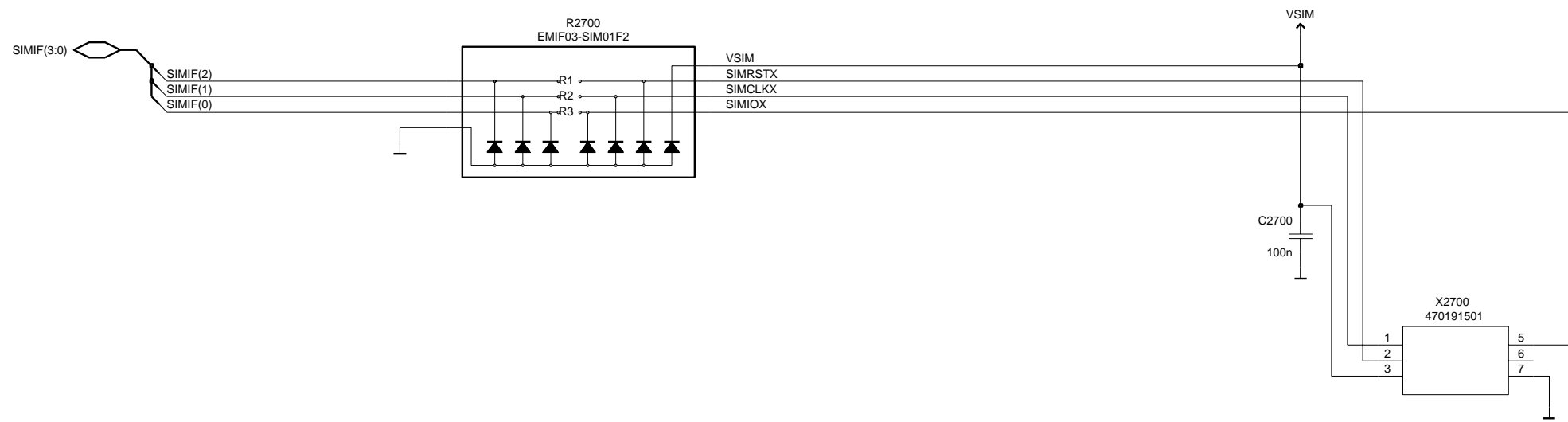

Key User Interface

version 10, edit 2

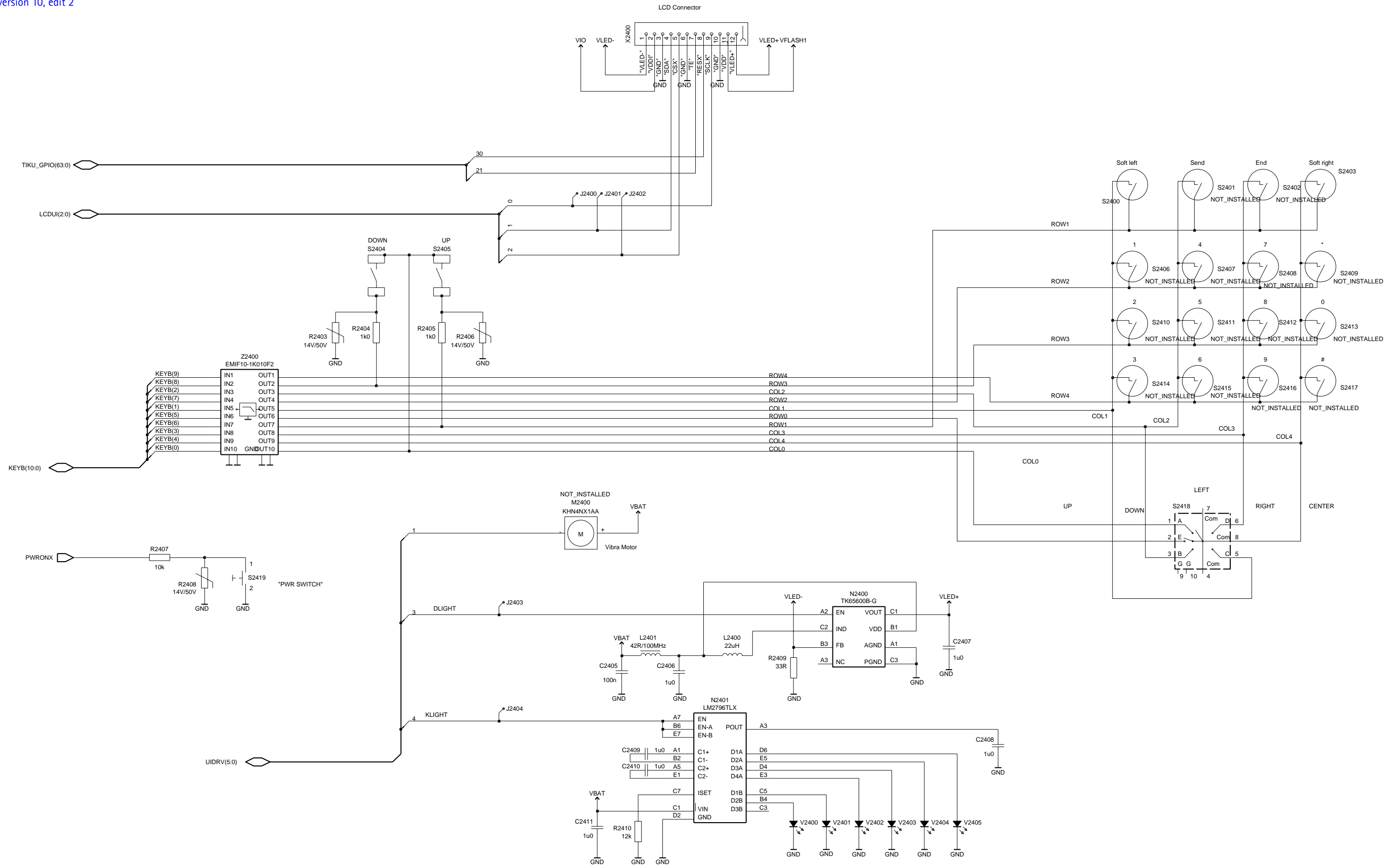

Infrared

version 10, edit 3

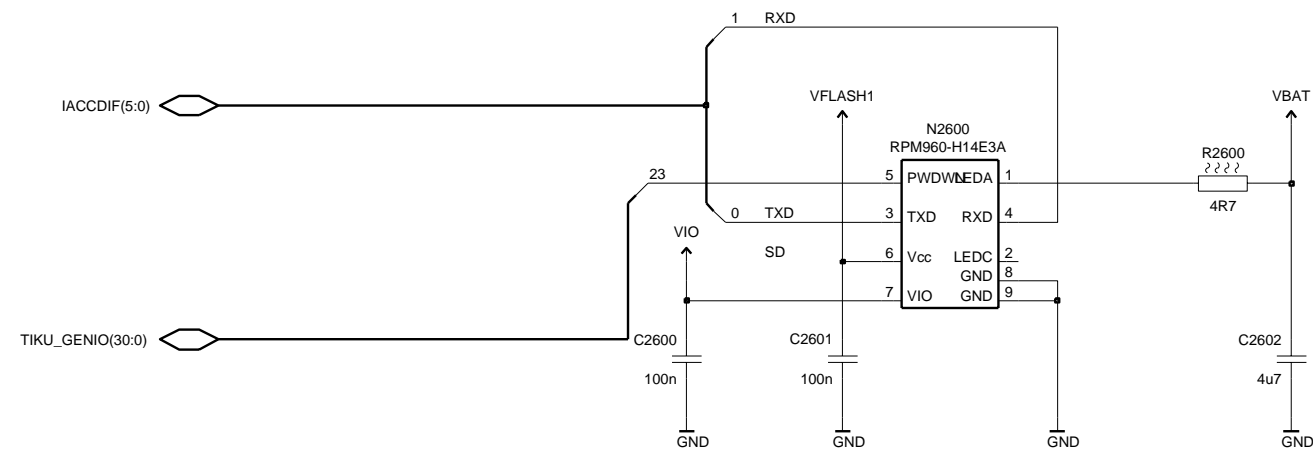

GPS Top Level

version 10, edit 2

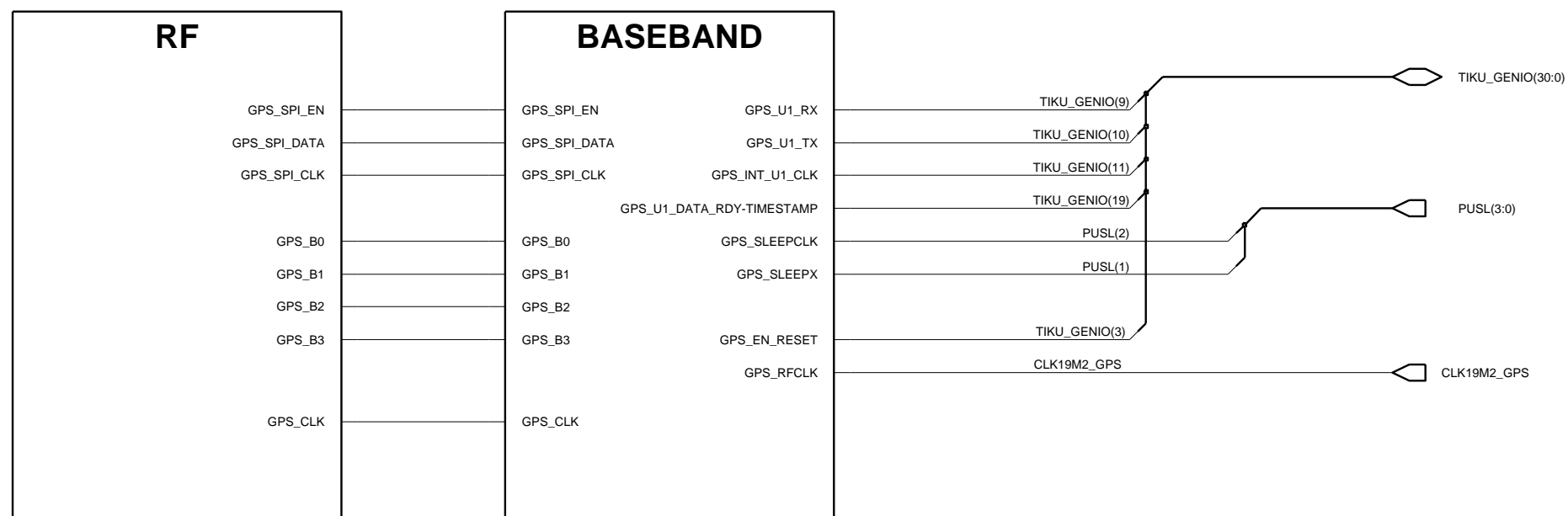

GPS RF

version 10, edit 2

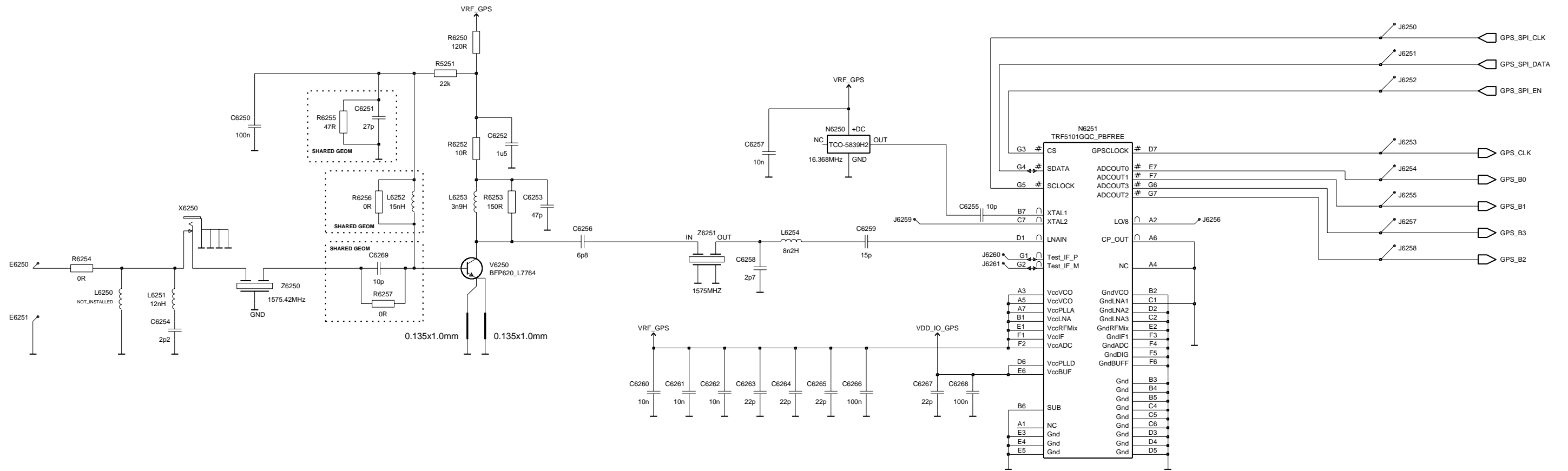

GPS BB

version 10, edit 2

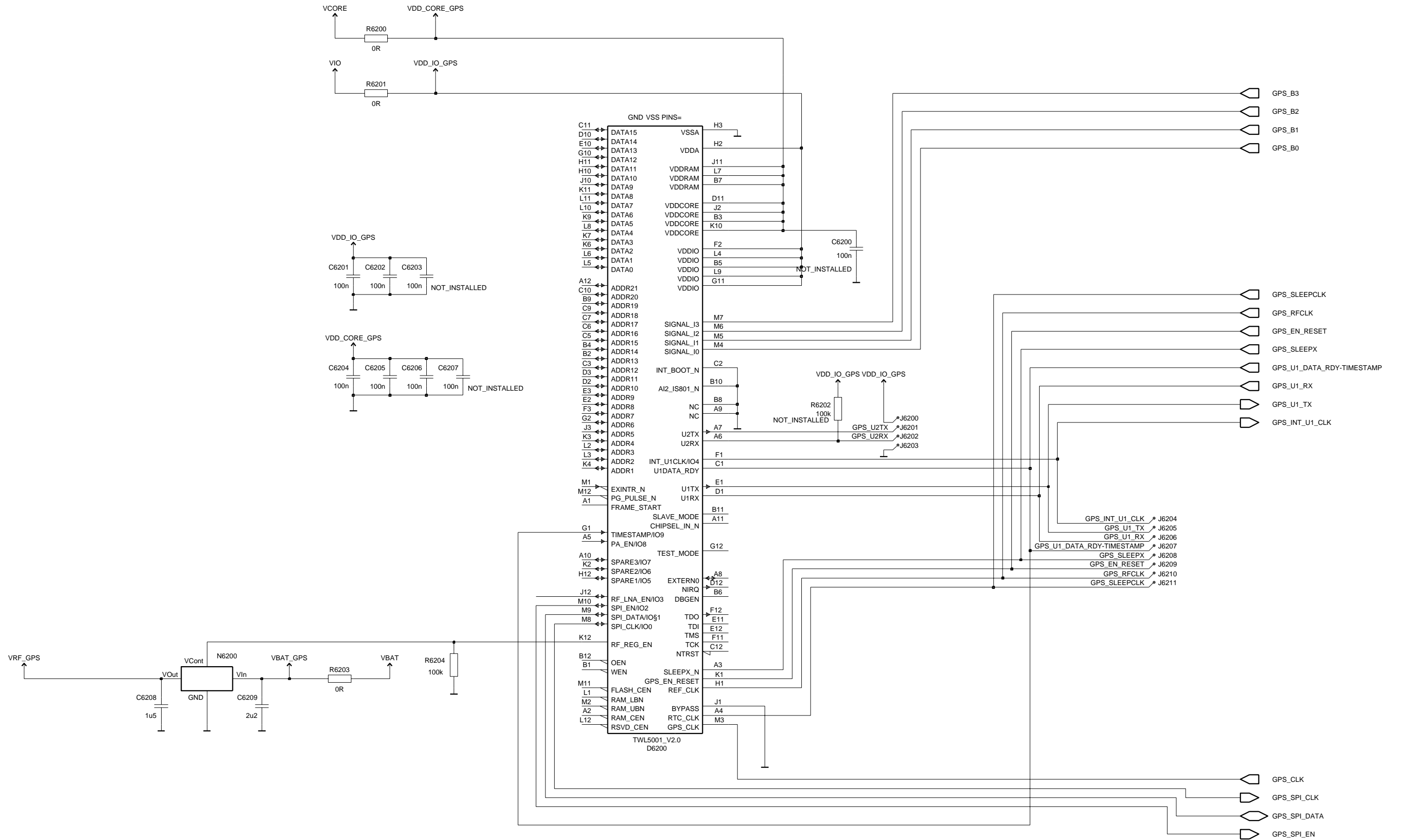

Camera

version 10, edit 3

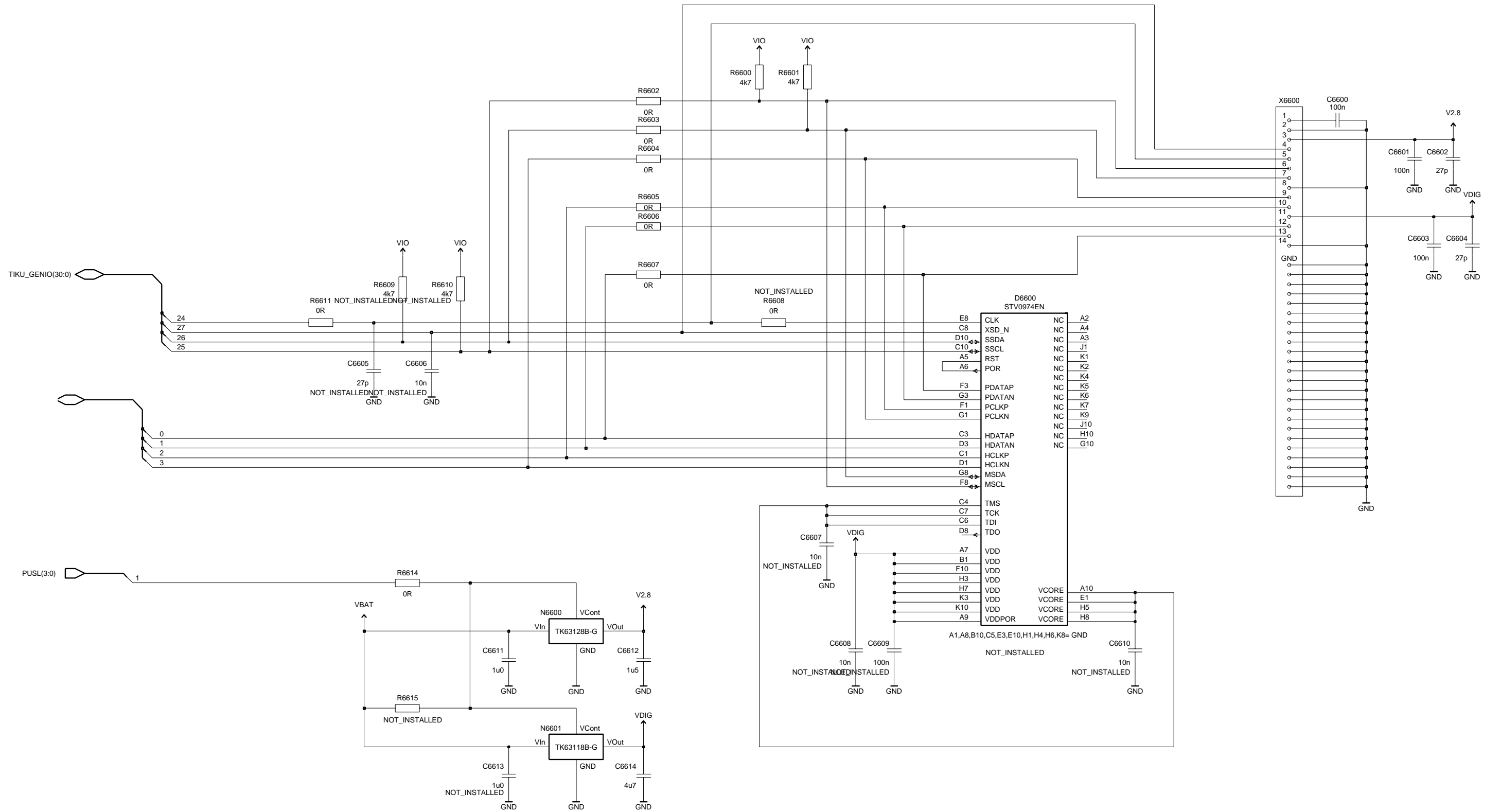

Memory

version 10, edit 3

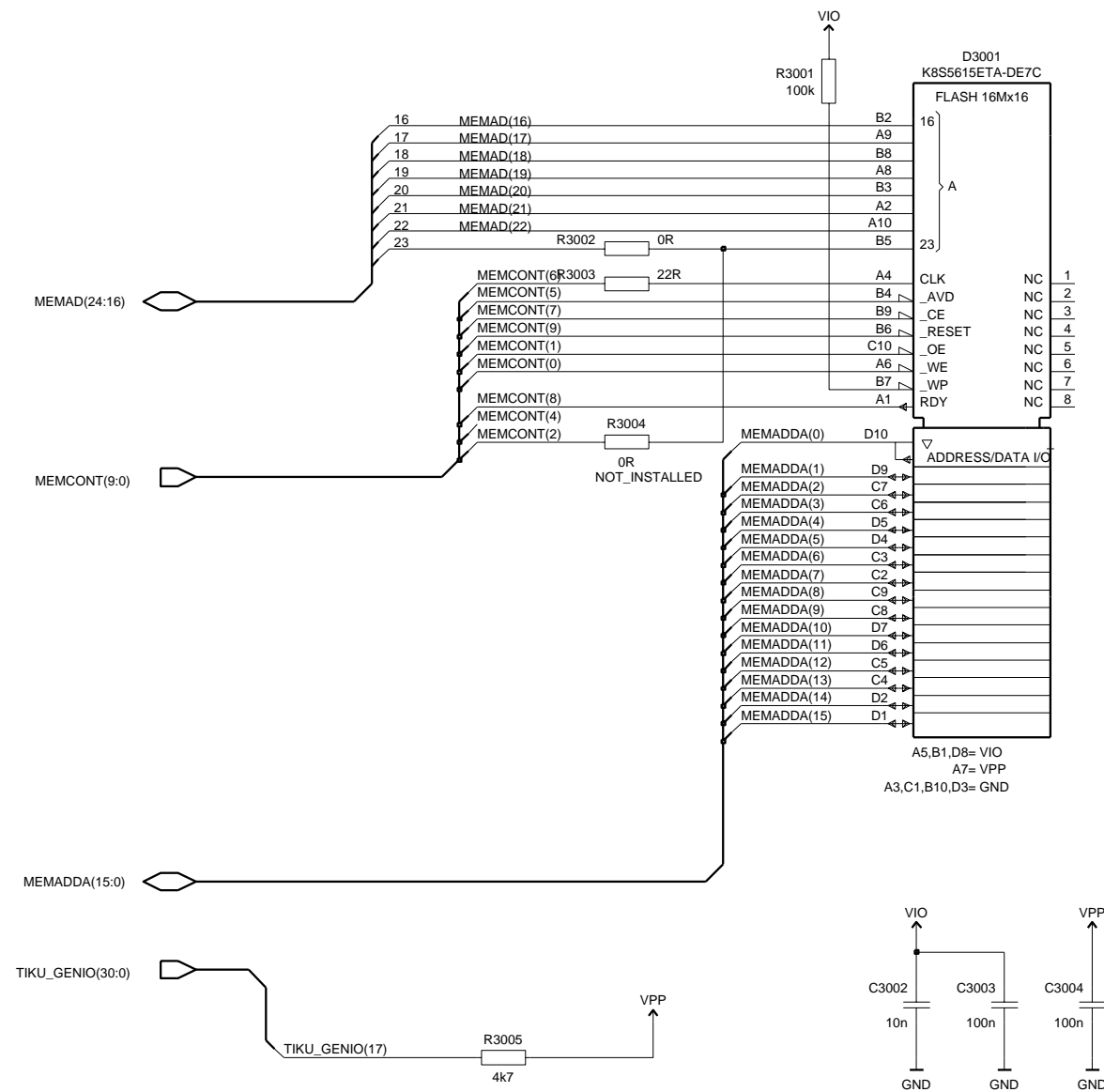

NOTE: Use R3004 for 128/128 NOR FLASH Pin B5 -> CE2
Use R3003 for 256M NOR FLASH Pin B5 -> A23

USE THE COMMON PART FOOTPRINT

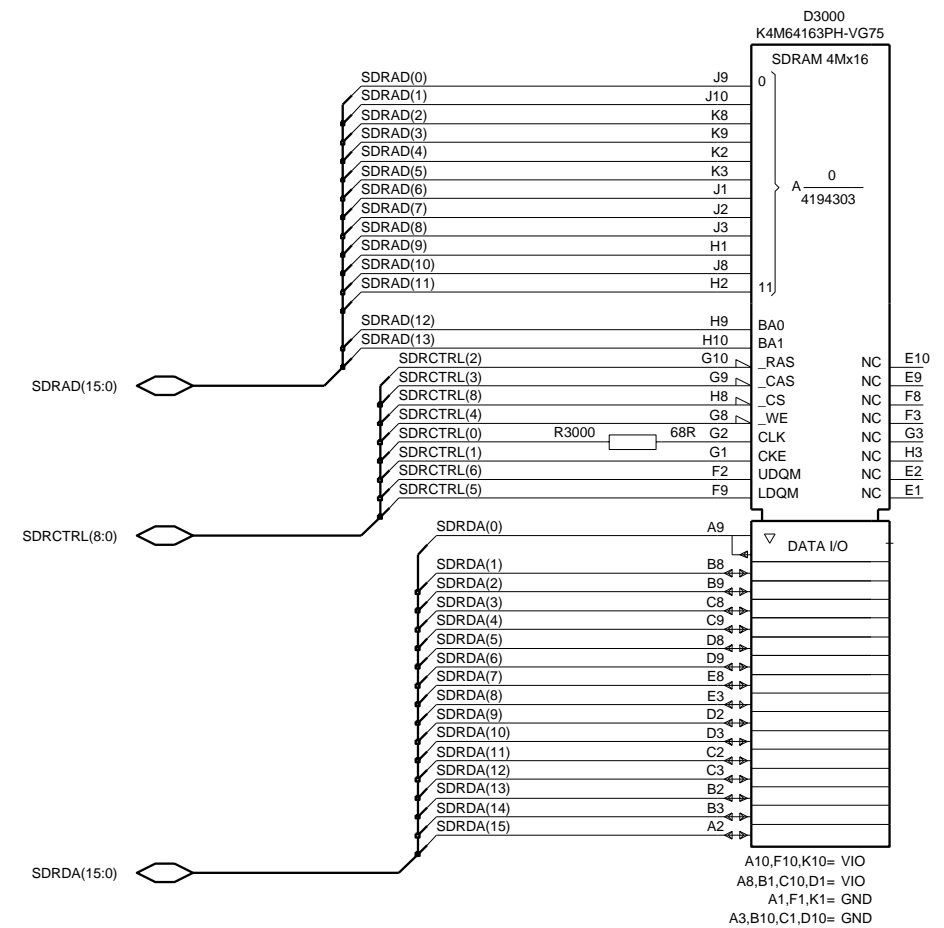

Test and Emulator Interface

version 10, edit 2

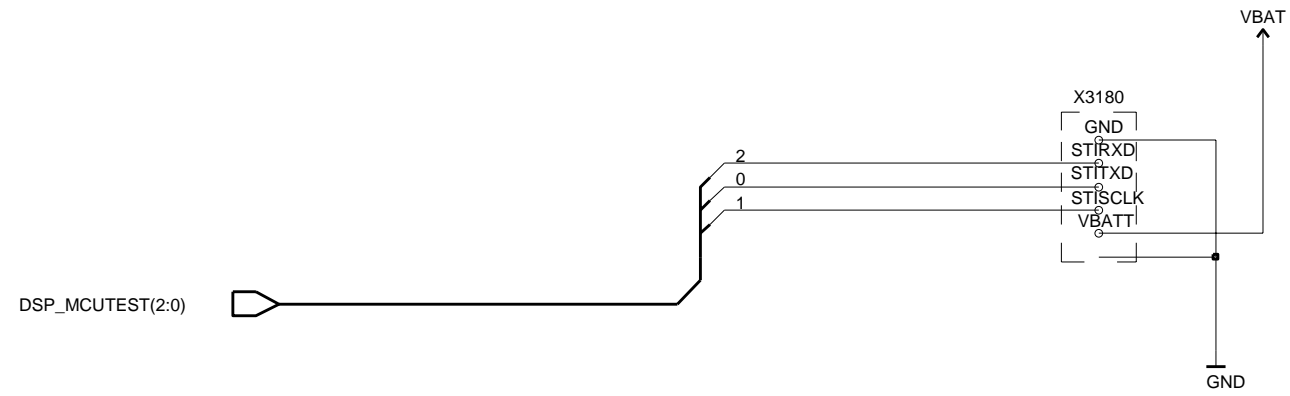

RF-BB Interface

version 10, edit 4

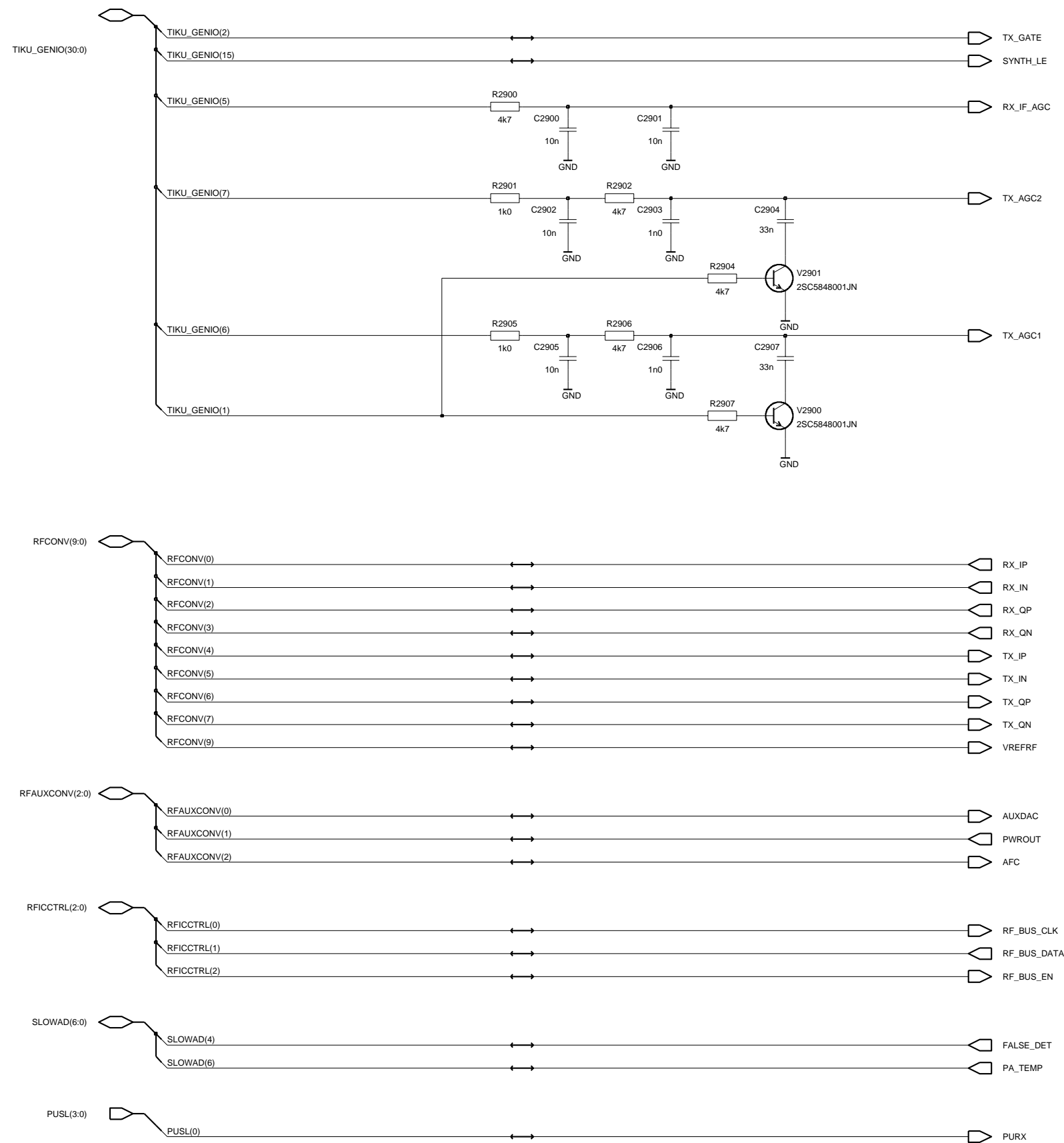

RF - Top Level

version 10, edit 2

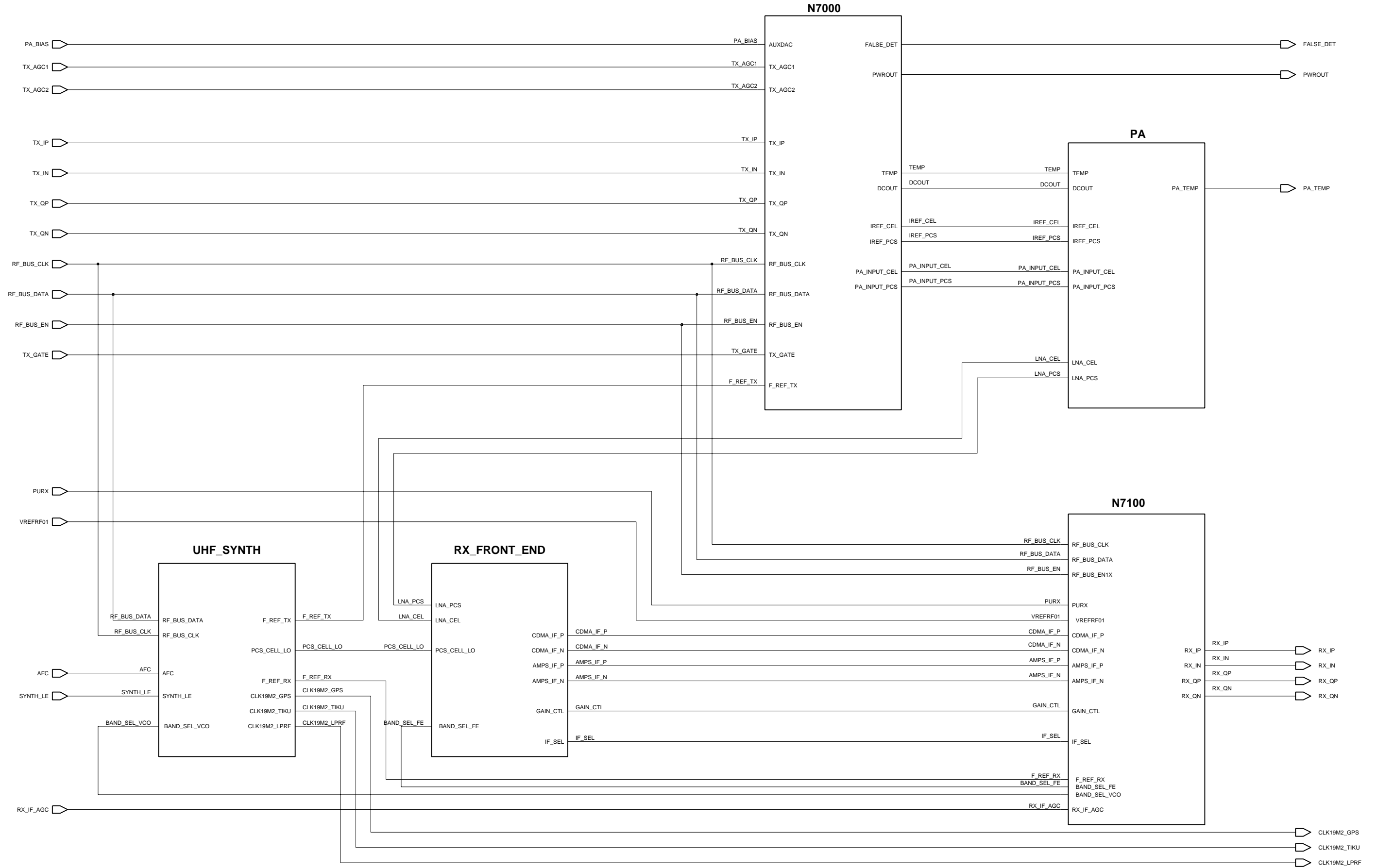

N7000

version 10, edit 2

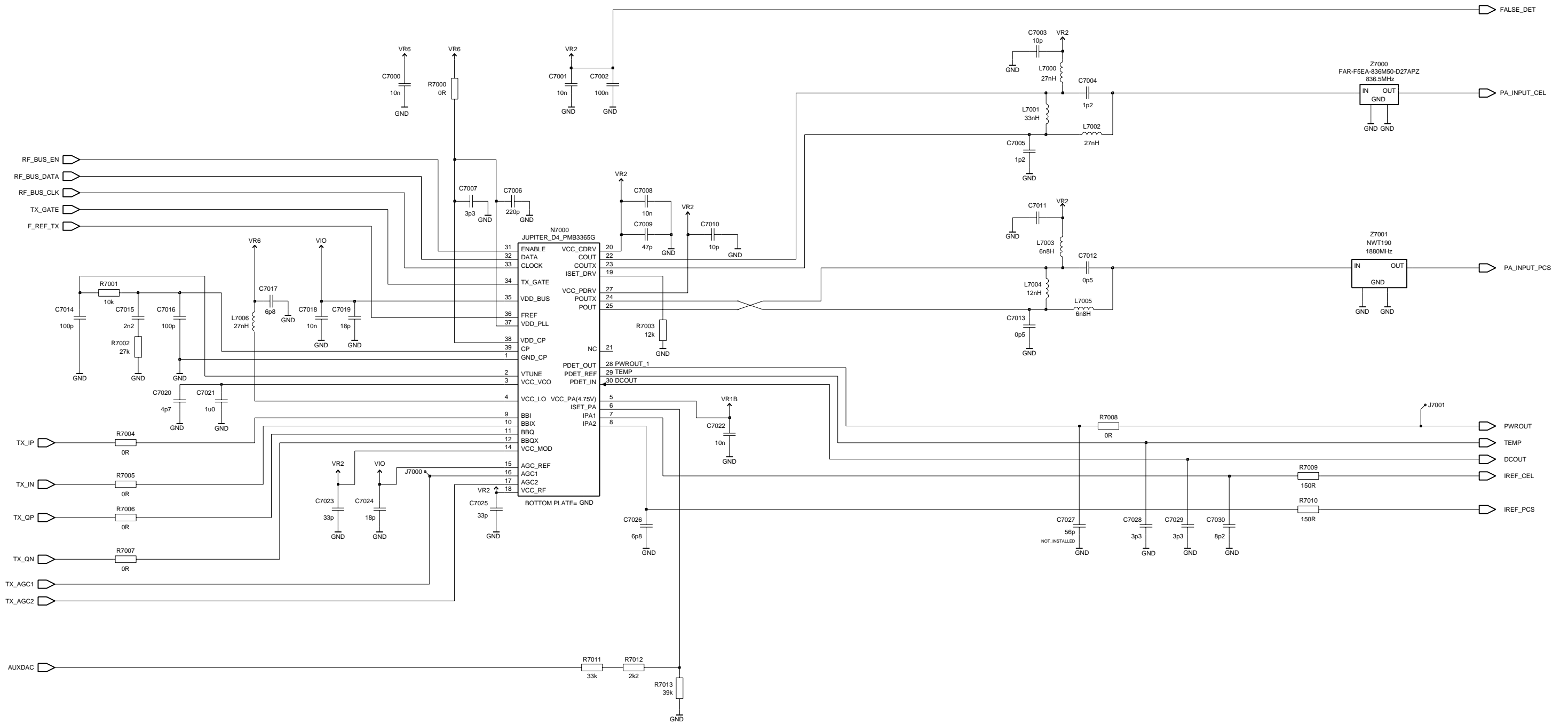

PA

version 10, edit 3

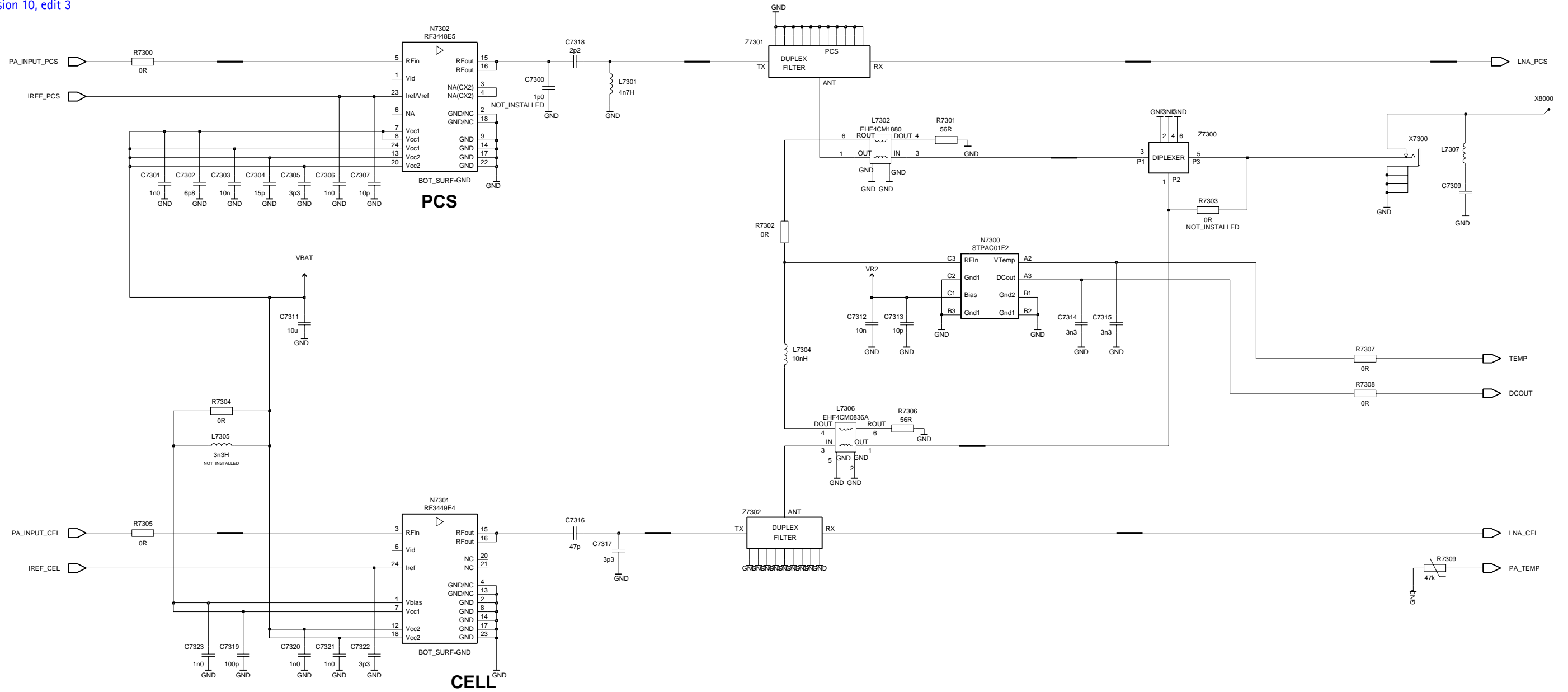

UHF Synthesizer

version 10, edit 2

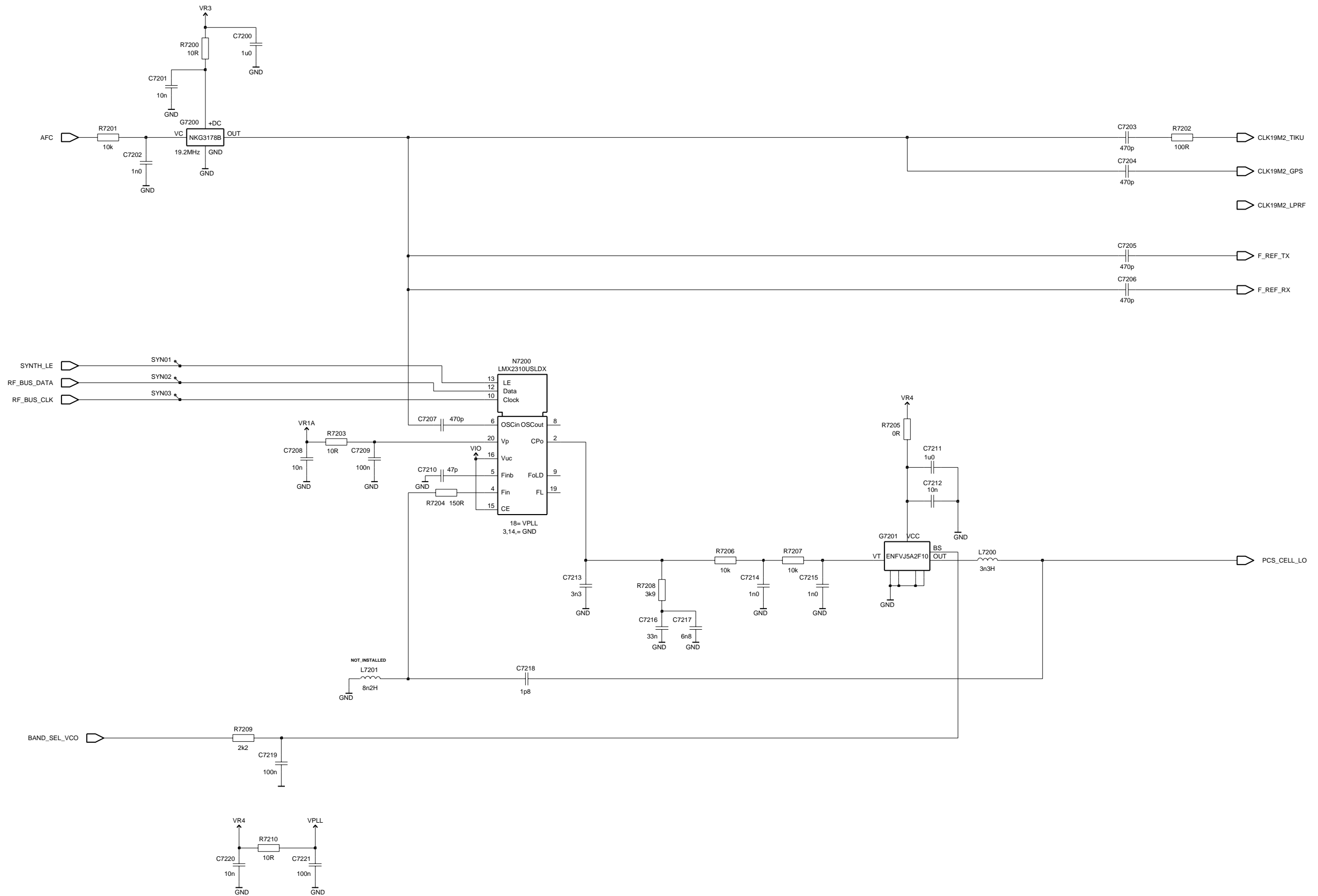

Front End (N7160)

version 10, edit 2

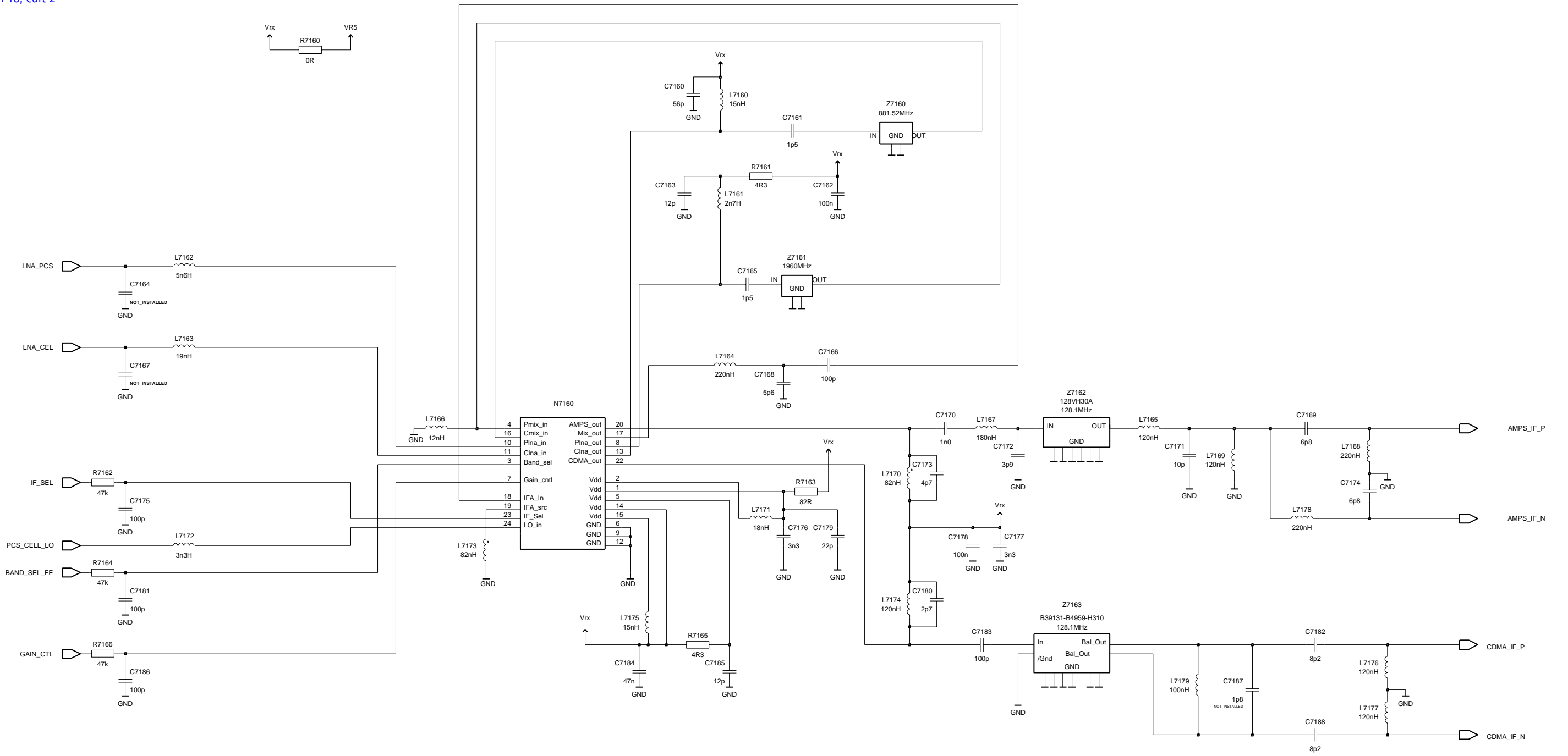

MODES	LOGIC INPUTS		
	BAND	GAIN_CTL	IF_SEL
CEL CDMA Hi Gain	0	1	0
CEL CDMA Lo Gain	0	0	0
PCS CDMA Hi Gain	1	1	0
PCS CDMA Lo Gain	1	0	0
AMPS Hi Gain	0	1	1
AMPS Lo Gain	0	0	1

Component Layout - Bottom

version 10

